

Presenting

proplanet P8 | Water Purifier



HOT IS THE NEW HEALTHY.



COMPLETE PROTECTION*



Baby-safe water with 8 stage purification



Instant purified hot water



Double protection with 100% RO+SCMT



Silver Nano Anti Bacterial Tank

✓ Patented Side Stream RO Membrane



Our patented side stream RO membrane removes bacteria, viruses, cysts, heavy metals like lead, mercury and arsenic, as well as pesticides and fluorides. The system is designed to ensure 100% of the water passes through the RO membrane and none of it bypasses it so no impurity stands a chance of passing through.

✓ 100% RO+SCMT

No Compromise, 100% purified water all the time with Double Protection of 100% RO+SCMT. SCMT (Silver Charged Membrane Technology) removes chemical reductions, phosphates, endotoxins, particulates etc, to give you healthy and pure drinking water.

RO+SCMT removes

- Bacteria
- Virus
- Particulates
- Cysts
- Endotoxins
- Colloids
- Phosphates
- Chemical Reduction
- ✓

RO+UV+UF removes

- Bacteria
- Virus
- Particulates
- Cysts
- Endotoxins
- Colloids
- Phosphates
- Chemical Reduction
- ✗

RO+UV removes

- Bacteria
- Virus
- Particulates
- Cysts
- Endotoxins
- Colloids
- Phosphates
- Chemical Reduction
- ✗



✓ Get Baby Safe Water with 8 Stage Purification

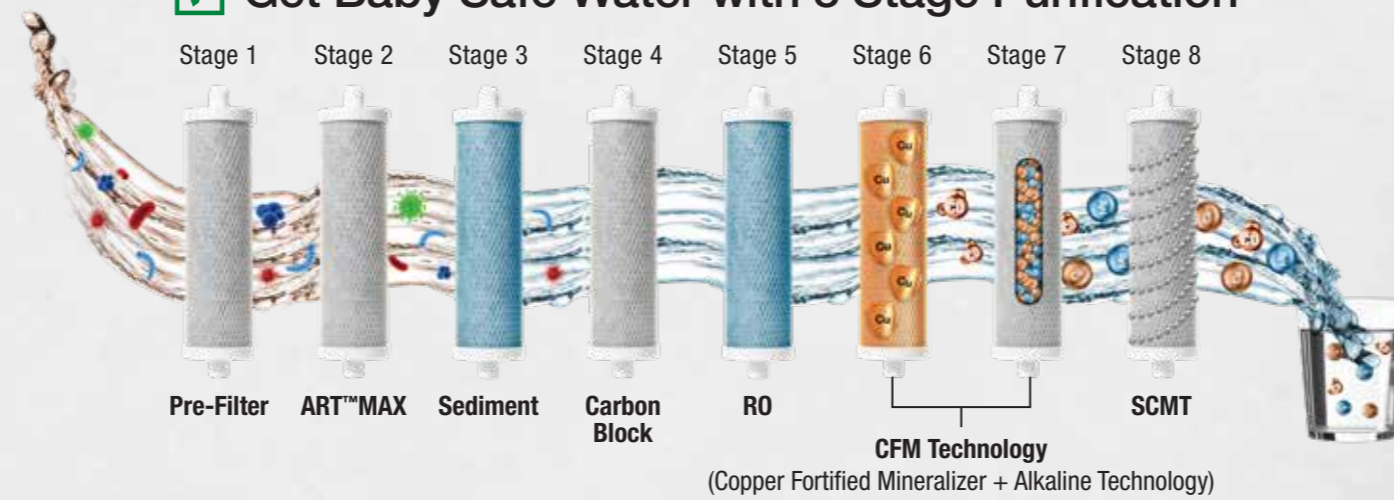

Get Baby Safe water-The ultra-comprehensive 8 stage purification process of the P8 amplifies water purity to its highest efficiency, always dispensing only safe and healthy drinking water, ensuring that the water you get is Baby Safe.

✓ CFM* Technology

Ensuring you get 100% RO purified water with all essential minerals & benefits of copper in it.



✓ Silver Nano Anti Bacterial Tank

P8 comes with an anti-bacterial storage tank (Silver Coating)

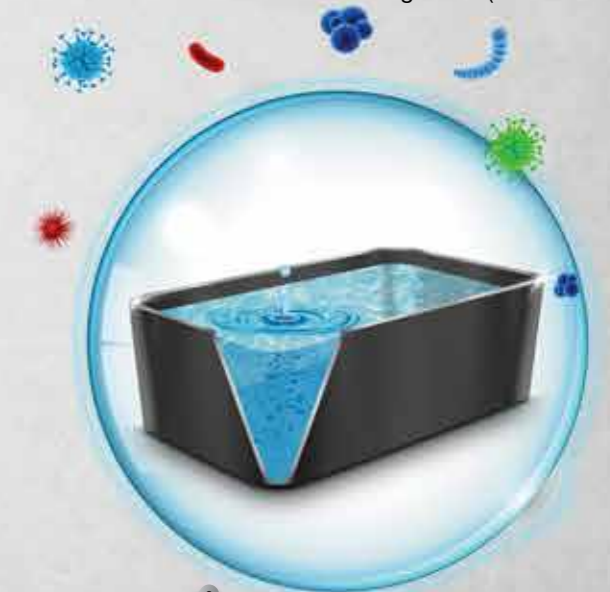

LIFE TIME WARRANTY ON TANK*



Bacterial Resistant - 99% reduction in bacterial growth resulting in purified and safe water



Patented Silver Technology - Reduces Microbial Growth



All Time Fresh - Inhibits Bacteria, keeping the purified water fresh 24x7

*T&C apply.



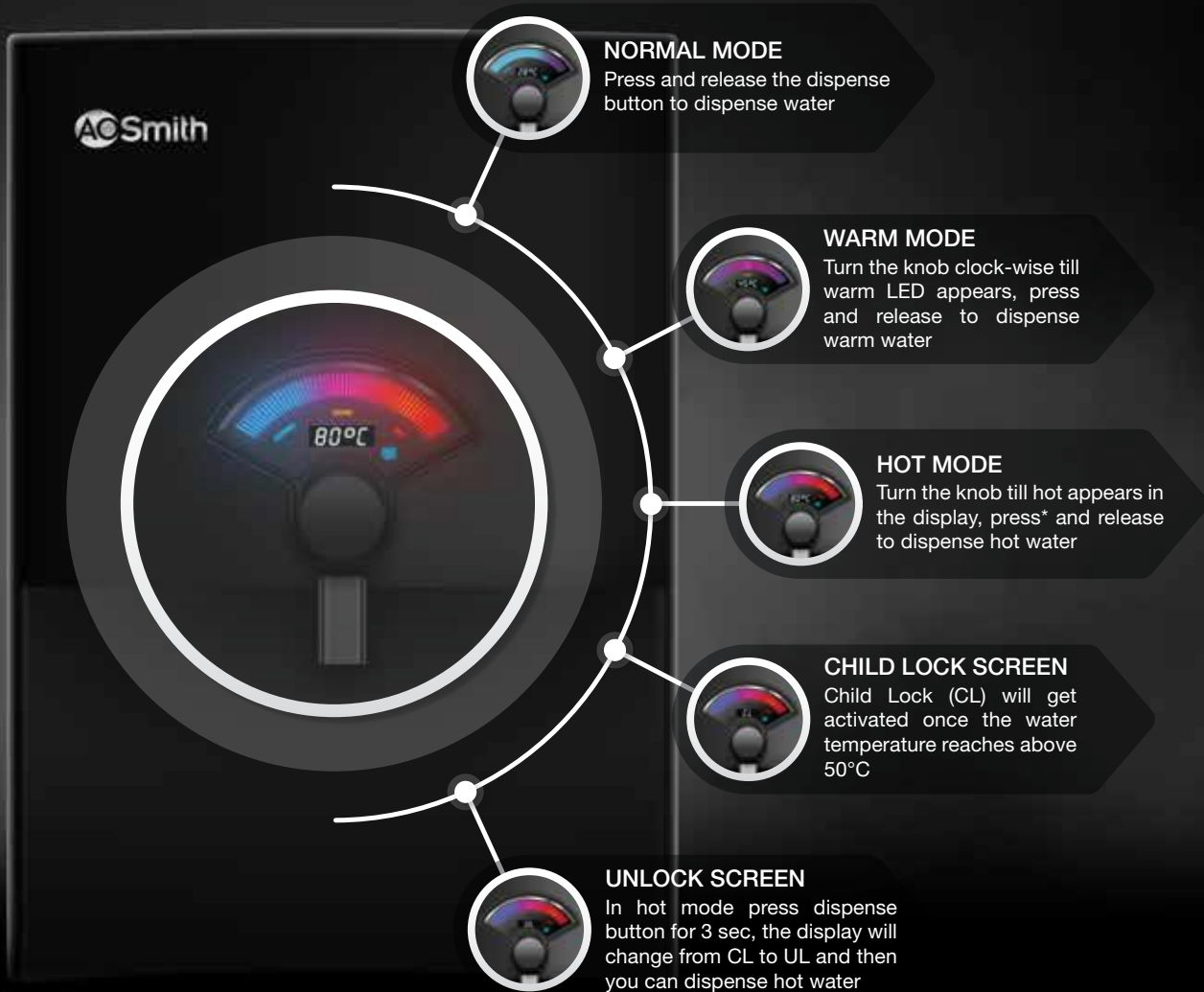

SCAN
P8 Usage Guide

*After unlocking child lock.

Specifications

Main Technology	RO + SCMT + CFM
No. of Stages	8 Stages
Storage Capacity	Upto 6.5 Ltrs (5.7L Ambient + 0.8L Hot)
Dimension (H x D x W) in mm	482 x 293 x 341
Pressure rating in psi [#]	2 ~ 30
Input Voltage in watt	150 ~ 300V AC / 50 Hz
Power rating watt (Max)	48
% Recovery [#]	60%
TDS reduction [#]	≥95% (approx.)
Water flow rate	Upto 15 Litres/hour
Suitable for TDS level	Upto 2000 ppm
Suitable for hardness level	Upto 500 ppm
1-Year Comprehensive Warranty	Yes (including all filters and RO membrane)

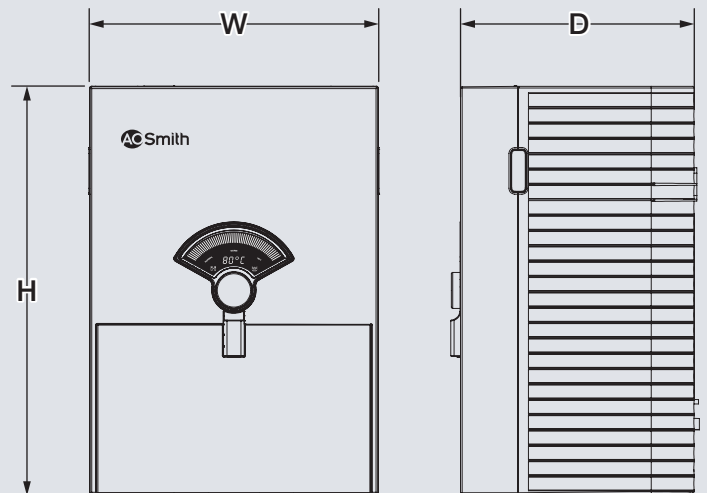

[#]For detailed specifications please refer product manual.



SCAN IT
TO KNOW MORE

AC Smith | Water Purifiers

Manufactured by
A. O. Smith India Water Products Private Limited
Plot No. 300, Phase - II, KIADB Industrial Area, Harohalli,
Kanakapura Taluk, Ramanagara District,
Karnataka - 562 112, India.
CIN: U31909KA2006PTC040282

Call **1860 500 2468** or visit www.aosmithindia.com

<https://www.facebook.com/aosmithin> | <https://twitter.com/AOSmithin> | <https://instagram.com/aosmithindia>